

Caratteristiche principali

Main Features

NFA 3

- Corpi e coperchi in ghisa per maggiori prestazioni
- Possibilità di funzionare ad alte pressioni: fino a 300 bar di pressione massima in funzionamento continuo.
- Compensazione assiale per il recupero dei giochi
- Alto rendimento volumetrico: >95% medio.
- Progetto accurato del profilo del dente per avere una bassa rumorosità.
- Disponibilità di guarnizioni per alte temperature
- Pompe e motori unidirezionali
- Pompe e motori bidirezionali
- Possibilità di montaggio di pompe multiple
- Cast iron covers and body for high performance
- High pressure option: up to 300 bar max. continuous pressure (4350 psi)
- Axial compensation achieved using pressure balanced bushing blocks.
- High volumetric efficiency: average 95%
- Gear tooth profile accurately projected providing low noise operation.
- High-temperature seals available.
- Single rotational pumps and motors.
- Bi-rotational pumps and motors.
- Multiple pumps availability: tandem pumps are possible both with other series

Condizioni di utilizzo

Working conditions

Nell'utilizzo della pompa evitare carichi radiali e assiali sull'albero, dove si verificano utilizzare gli appositi supporti illustrati in questo catalogo Il giunto di trascinarsi deve compensare eventuali errori di allineamento, deve essere di tipo elastico oppure di tipo Oldham.

Per un corretto funzionamento e una lunga durata della pompa, osservare i valori riportati nella tabella a pag. 8-9.

Avoid radial and axial loads on the pump shaft during the use, where it happens use outboard bearing illustrated in this catalogue. The pump must be in line with the P.T.O. to compensate misalignment errors, use flexible or "Oldham" coupling. We recommend to read the specifications in this catalogue very carefully. This will help you in getting the best, in terms of working conditions and life, from Ronzio gear pumps.





Caratteristiche principali

Main characteristics

Tipo - Type		25	35	45	55	64	80
Glindrata Capacity	Cm ³ /giro Cm ³ /rev	24.9	34.3	45.2	54.5	63.9	78.7
Portata a 1500 giri / min Delivery at 1500 rev. / min	l/min l/min	37.4	51.5	67.8	81.8	95.9	118
P1 Pressione max continua Max working pressure	Bar	300	290	280	250	230	190
P2 Pressione intermittente intermittent pressure	Bar	320	300	290	270	250	220
P3 Pressione max di picco Max peak pressure	Bar	350	330	310	290	260	230
Velocità max per pressione P1 Max speed for P1 pressure	Giri / min Rpm	3000	2500	2200	2000	2000	1800
Velocità max a vuoto Max speed without load	Giri / min Rpm	3500	3000	2800	2500	2500	2200
Velocità min. per pressione P1 Min speed for P1 pressure	Giri / min Rpm	450	350	350	300	250	200

VERIFICARE, ATTRAVERSO LE FORMULE SEGUENTI LA COMPATIBILITÀ TRA LE PRESTAZIONI DI PRESSIONE E PORTATA RICHIESTE E LA CAPACITÀ DELL' ALBERO DI TRASCINAMENTO DI SOPPORTARE LA COPPIA RICHIESTA.

VERIFY THE COMPATIBILITY AMONG PERFORMANCE OF PRESSURE, FLOW REQUIRED AND TORQUE OF THE SHAFT THROUGH THE BELOW FORMULAS.

Per pompe o motori bidirezionali, diminuire la pressione del 15%.

With bidirectional pumps or motors, pressure is reduced by 15%.

Formule per il dimensionamento

Determination of nominal size

PER POMPE

$$Q = \frac{V \cdot \eta_v \cdot n}{1000}$$

$$M = \frac{p \cdot V}{62.8 \cdot \eta_m}$$

$$P = \frac{p \cdot Q}{600 \cdot \eta_t}$$

PER MOTORI

$$Q = \frac{V \cdot n}{1000 \cdot \eta_v}$$

$$M = \frac{p \cdot V \cdot \eta_m}{62.8}$$

$$P = \frac{p \cdot Q \cdot \eta_t}{600}$$

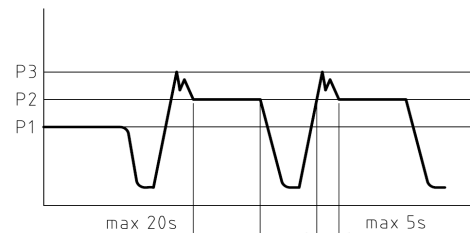

V [cm³]

Q [l/min]

p [bar]

M [Nm]

$\eta_v = \text{EFF vol.} \geq 95$

Condizioni di utilizzo

Use conditions

NFA 3

Fluidi idraulici Hydraulic fluids	<p>Oli idraulici a base minerale (DIN 51524). Per utilizzo di fluidi non infiammabili come acqua e glicole, emulsione di olio in acqua o esteri fosforici, contattare il nostro ufficio tecnico o commerciale.</p> <p>Mineral oil (DIN 51524). For use with fire resistant fluids like water glycol, water-oil emulsion and phosphate-esters, contact our technical or commercial office.</p>
--------------------------------------	-------------------------------------------------------------------------------------------------------------------------------------------------------------------------------------------------------------------------------------------------------------------------------------------------------------------------------------------------------------------------------------------------------

Pressione in aspirazione Inlet pressure	0.7 - 3 bar (Assoluti / Absolute) 10 - 44 psi (Assoluti / Absolute)
Velocità olio nella linea di aspirazione Oil speed on suction line	0.5 ÷ 1.5 m/s
Velocità olio nella linea di mandata Oil speed on pressure line	6 ÷ 10 m/s
Temperatura olio Oil temperature	-10°C ÷ 80°C
Viscosità olio Oil viscosity	20 ÷ 120 mm ² /s (Cst)
Massima viscosità olio all'avvio Max starting viscosity	700 mm ² /s (Cst)

Filtraggio olio Oil filtration	Pressione (bar) Pressure (bar)	< 140	140 > 210	>210
	Classe di contaminazione NAS 1638 Contamination class NAS 1638	10	9	8
	Classe di contaminazione ISO 4406:1999 Contamination class ISO 4406:1999	21/19/16	20/18/15	19/17/14
	Rapporto $\beta_{10} \geq 75$ - ISO16889 Ratio $\beta_{10} \geq 75$ - ISO16889	//	10 μ m	10 μ m
	Rapporto $\beta_{25} \geq 200$ - ISO16889 Ratio $\beta_{25} \geq 200$ - ISO16889	25 μ m	//	//

Diagrammi

Diagrams

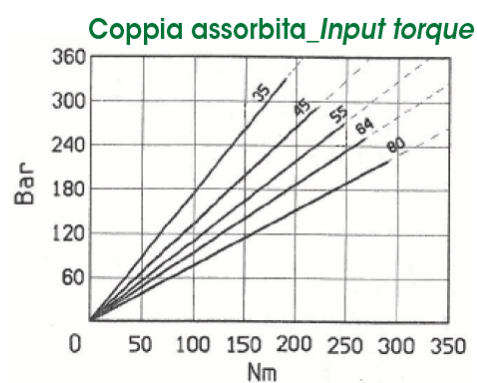
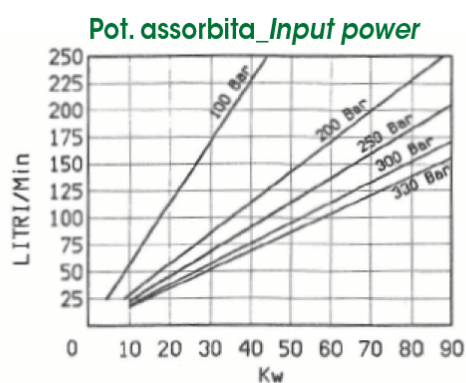
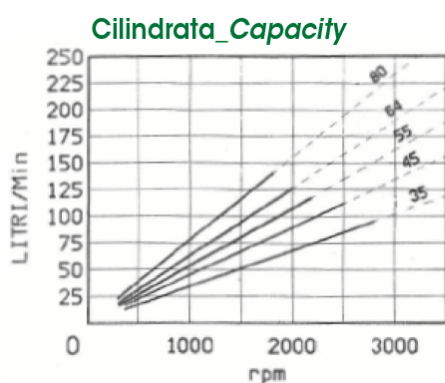

Condizioni di utilizzo

Use conditions

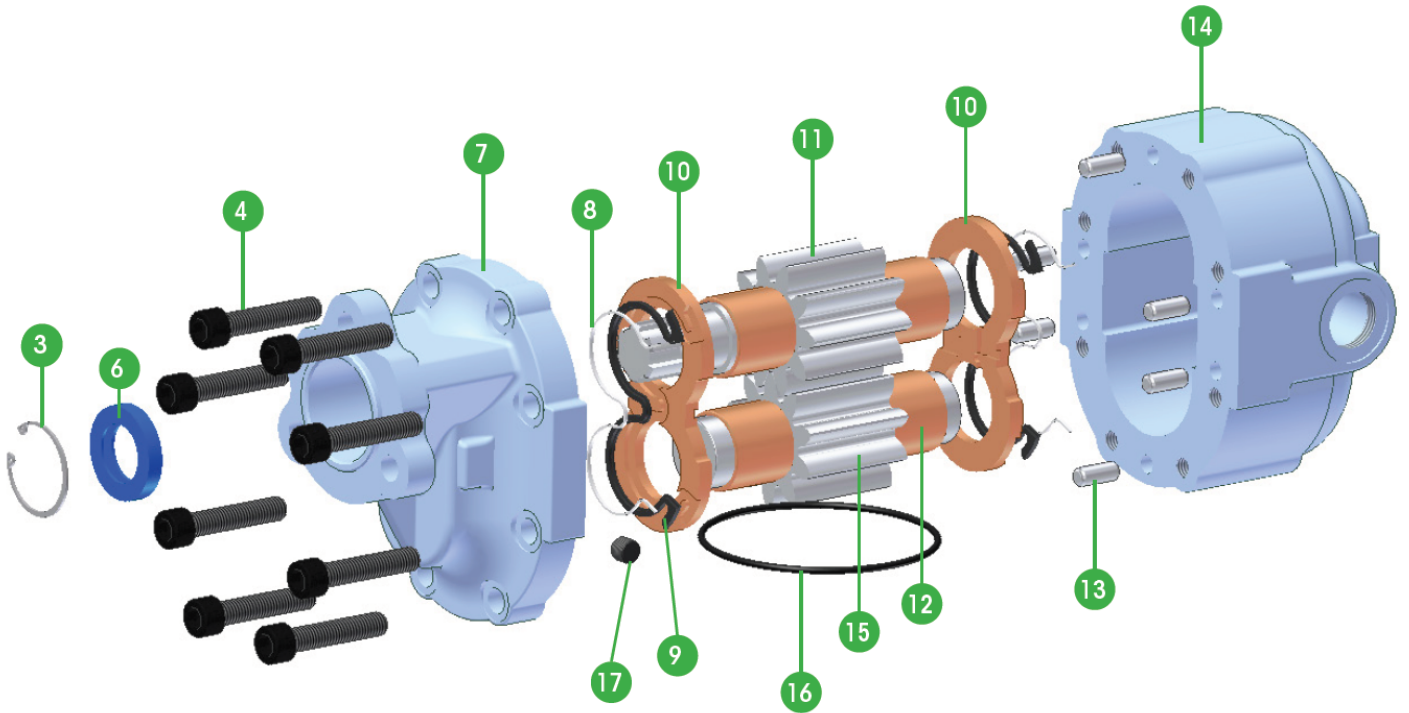

Rif.	Descrizione	Description	Qt.
3	Anello seeger	Snap ring	1
4	Vite	Bolt	8
6	Guarnizione albero	Rotary shaft seal	1
7	Coperchio	Front flange	1
8	Antiestrusore	B-K seals	2
9	Guarnizione di compensazione	Compensation seal	2
10	Rasamento	Thrust plates	2
11	Ingranaggio conduttore	Drive gear	1
12	Boccola	Bushing	4
13	Spina cilindrica	Pin	6
14	Corpo	Housing	1
15	Ingranaggio condotto	Idle gear	1
16	Guarnizione sotto coperchio	Under cover seal	1
17	Grano 1/8" G	Grub screw 1/8" G	1

Cambio senso di rotazione Changing rotation of the pump

Rotazione DX
CW rotation

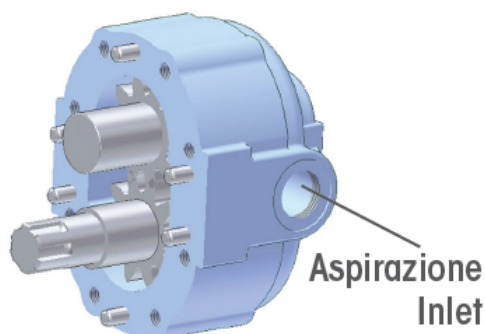
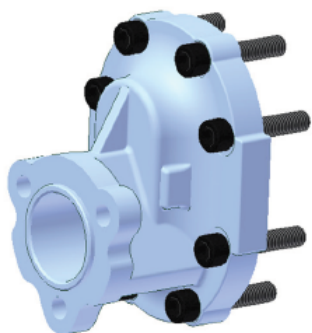

Il senso di rotazione, è indicato con una freccia sul corpo della pompa
An arrow on the housing of the pump indicates the rotation

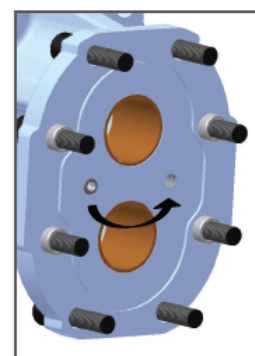

Rotazione SX
CCW rotation

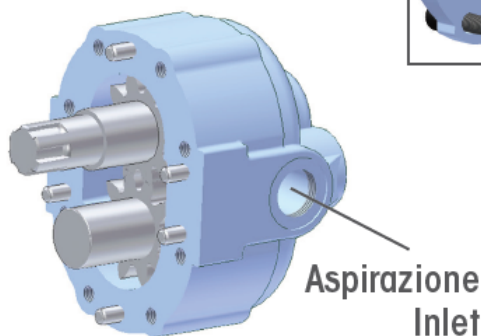

- Svitare le viti di fissaggio.
- Rimuovere la flangia tenendo premuto l'ingranaggio conduttore.
- Rimuovere contemporaneamente l'ingranaggio conduttore e il rasamento superiore mantenendo premuto l'ingranaggio condotto.
- Estrarre l'ingranaggio condotto tenendo fermo il rasamento inferiore, nel caso aiutarsi con una barretta NON metallica.
- Rimontare i due ingranaggi con posizioni invertite (vedi schema sopra).
- Rimontare il rasamento superiore facendo attenzione a NON invertirne la posizione.
- Cambiare di posizione al grano situato sulla faccia interna della flangia.
- Rimontare la flangia utilizzando per le viti una coppia di serraggio di 60-65 Nm.

- Unscrew the clamping bolts.
- Remove the flange holding down the drive gear.
- Remove the drive gear and the bushing block holding down the idle gear.
- Remove the idle gear keeping down the rear bushing block with a no-metallic bar.
- Reverse the position of the two gears (see picture above).
- Replace the bushing block without rotate or changing position.
- Changing position of the grub screw on the flange (see picture above).
- Reverse the flange and retighten the bolts to a torque rating between 44-48 ft/lbs.



Pompe ad ingranaggi Gear Pumps

Come ordinare / How to order

032NFA 025 00 S

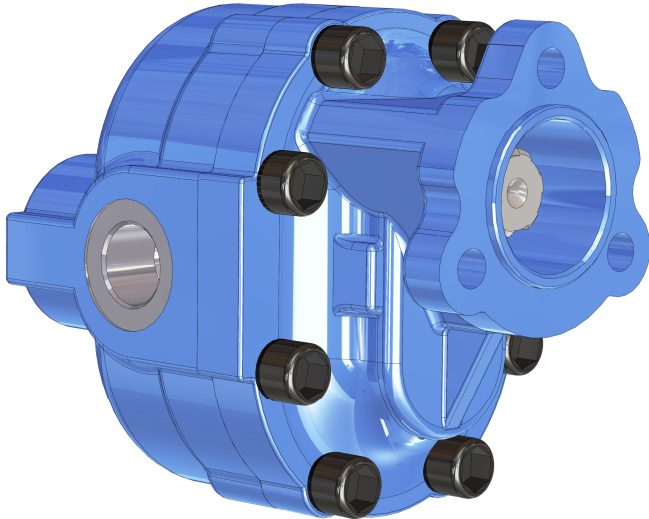

ROTAZIONE

Rotation

D = destra / CW

S = sinistra / CCW

R = reversibile /
bidirectional

CILINDRATA

capacity

TIPO POMPA

Pump type

MAX TORQUE 280 Nm

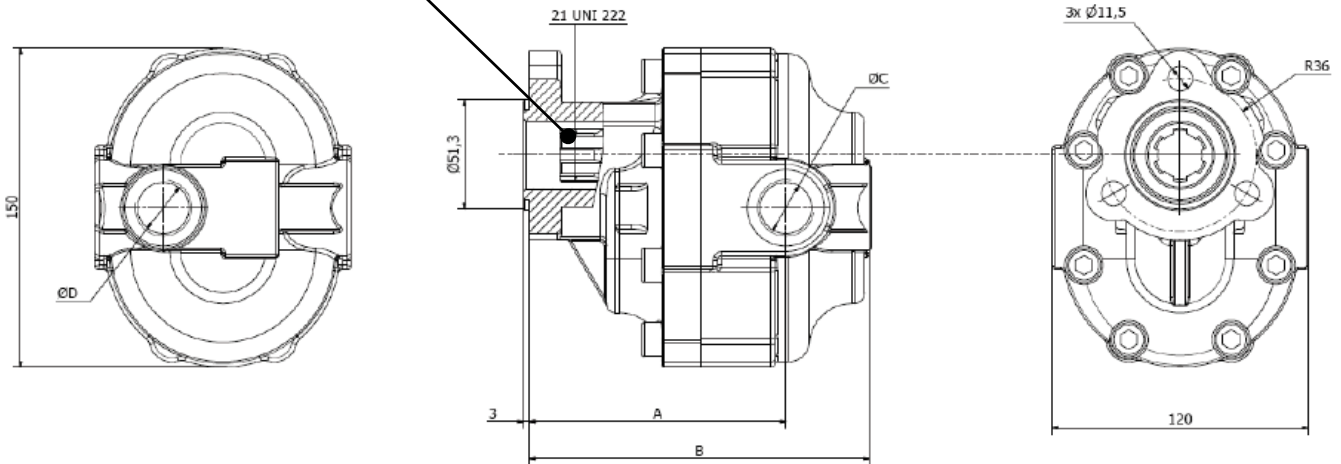

TIPO type	cm ³ /rev	A	B	C			Kg
				IN	OUT	BIDIR.	
032NFA-025	24,9	145	175	3/4"	1/2"	3/4"	11,6
032NFA-035	34,3	141	187	3/4"	1/2"	3/4"	12,6
032NFA-045	45,2	131	194	1"	3/4"	1"	13,1
032NFA-055	54,5	137	200	1"	3/4"	1"	13,7
032NFA-064	63,9	143	206	1"	3/4"	1"	14,5
032NFA-080	78,7	143	216	1"-1/4	1"	1"-1/4	14,8

Pompe ad ingranaggi Gear Pumps



Come ordinare / How to order

032NFA 025 E0 D

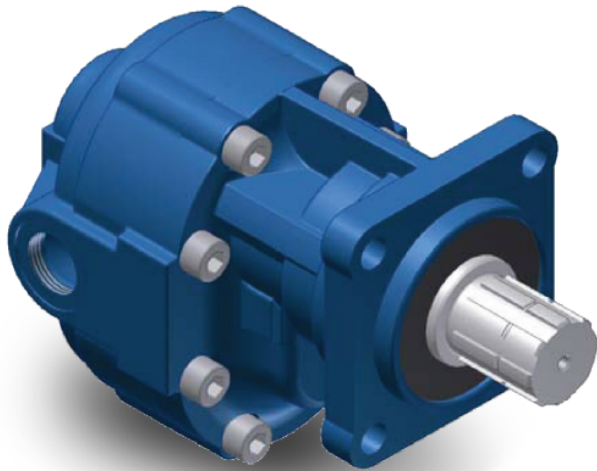

ROTAZIONE
Rotation
D = destra / CW
S = sinistra / CCW
R = reversibile /
bidirectional

CILINDRATA
capacity

TIPO POMPA
Pump type

MAX TORQUE 280 Nm

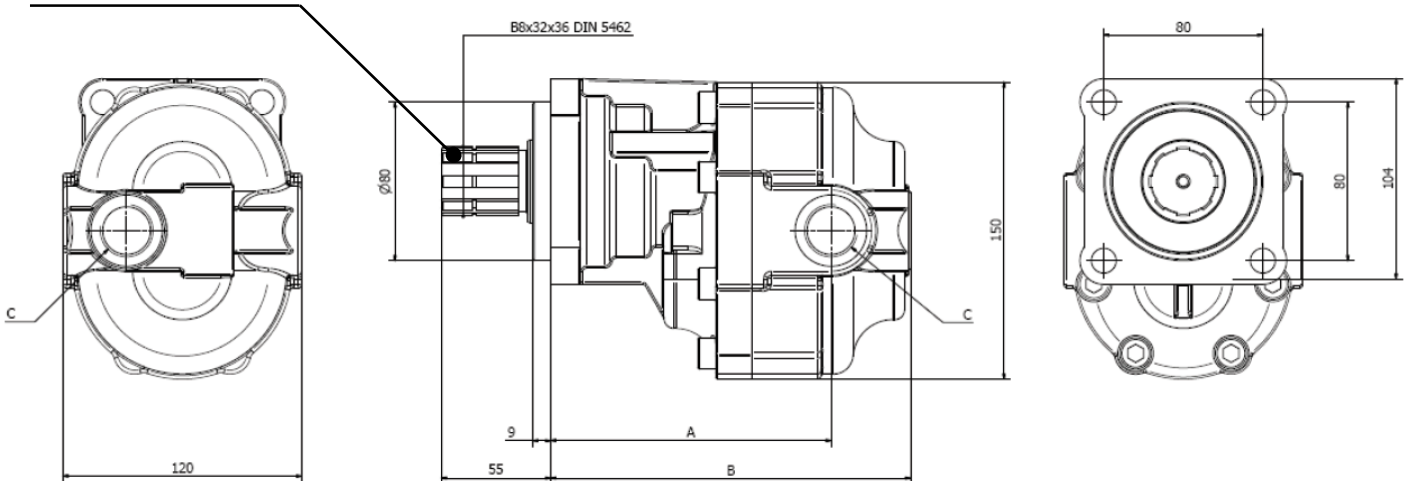

TIPO type	cm ³ /rev	A	B	C			Kg
				IN	OUT	BIDIR.	
032NFA-025	24,9	145	175	3/4"	1/2"	3/4"	13,8
032NFA-035	34,3	141	187	3/4"	1/2"	3/4"	14,8
032NFA-045	45,2	131	194	1"	3/4"	1"	15,3
032NFA-055	54,5	137	200	1"	3/4"	1"	15,9
032NFA-064	63,9	143	206	1"	3/4"	1"	16,7
032NFA-080	78,7	143	216	1"-1/4	1"	1"-1/4	17,1



Pompe tandem ad ingranaggi Tandem Gear Pumps

Come ordinare / How to order

032NFA 035 OT S

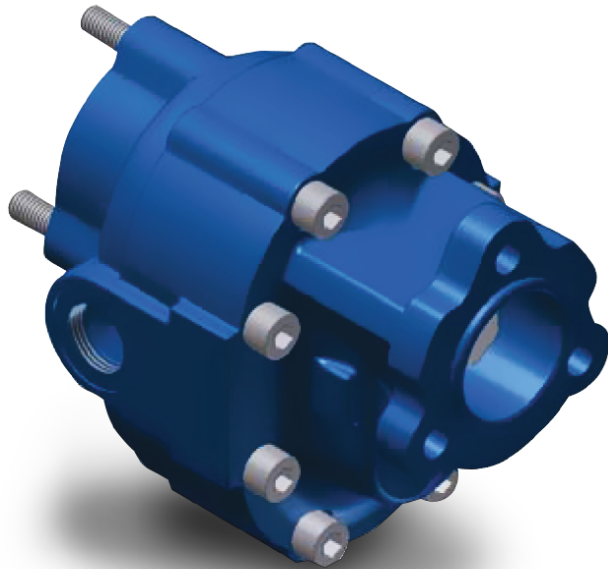

ROTAZIONE
Rotation
D = destra / CW
S = sinistra / CCW
R = reversibile /
bidirectional

CILINDRATA
capacity

TIPO POMPA
Pump type

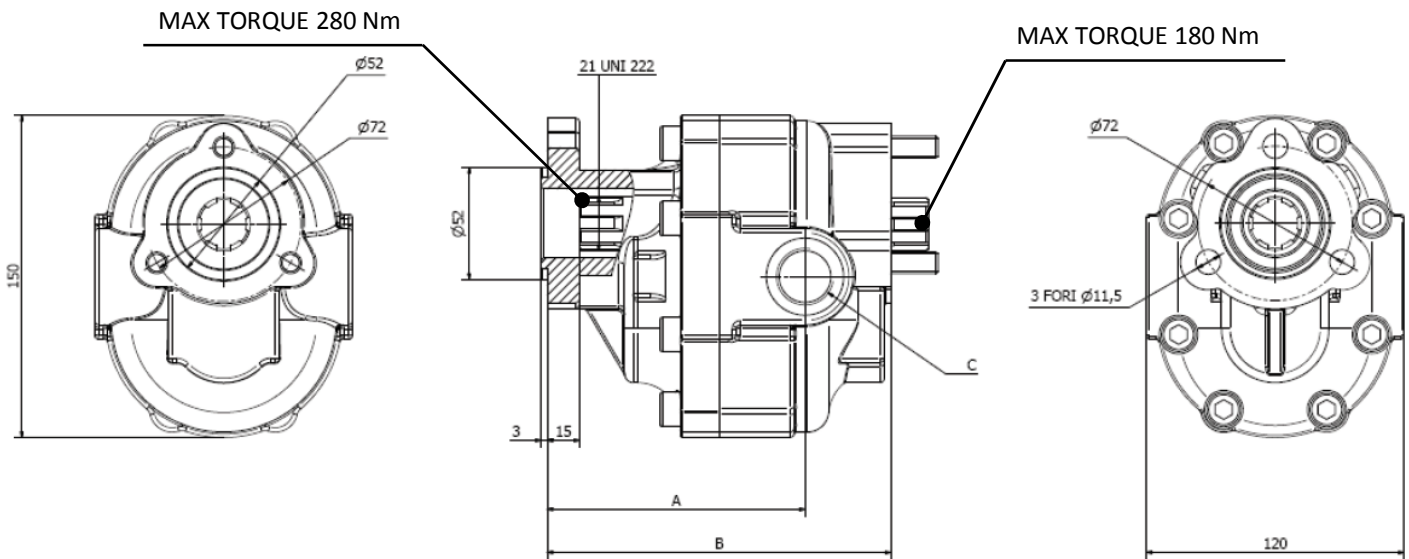

TIPO type	cm ³ /rev	A	B	C			Kg
				IN	OUT	BIDIR.	
032NFA-035	34,3	141	187	3/4"	1/2"	3/4"	12,6
032NFA-045	45,2	131	194	1"	3/4"	1"	13,1
032NFA-055	54,5	137	200	1"	3/4"	1"	13,7
032NFA-064	63,9	143	206	1"	3/4"	1"	14,5
032NFA-080	78,7	143	216	1"-1/4	1"	1"-1/4	14,8

Pompe tandem ad ingranaggi Tandem Gear Pumps

NFA3TD
ISO

Come ordinare / *How to order*

032NFA 035 ET D

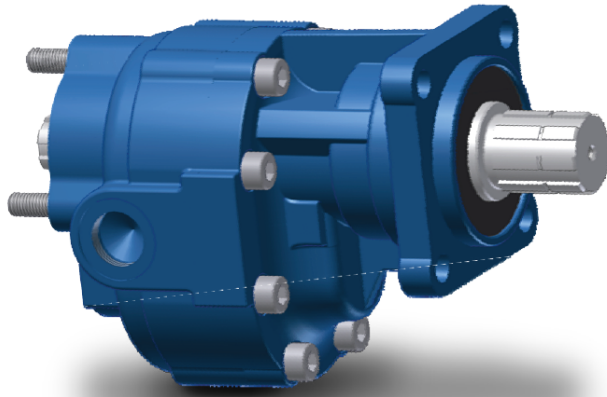

ROTAZIONE
Rotation
D = destra / CW
S = sinistra / CCW
R = reversibile /
bidirectional

CILINDRATA
capacity

TIPO POMPA
Pump type

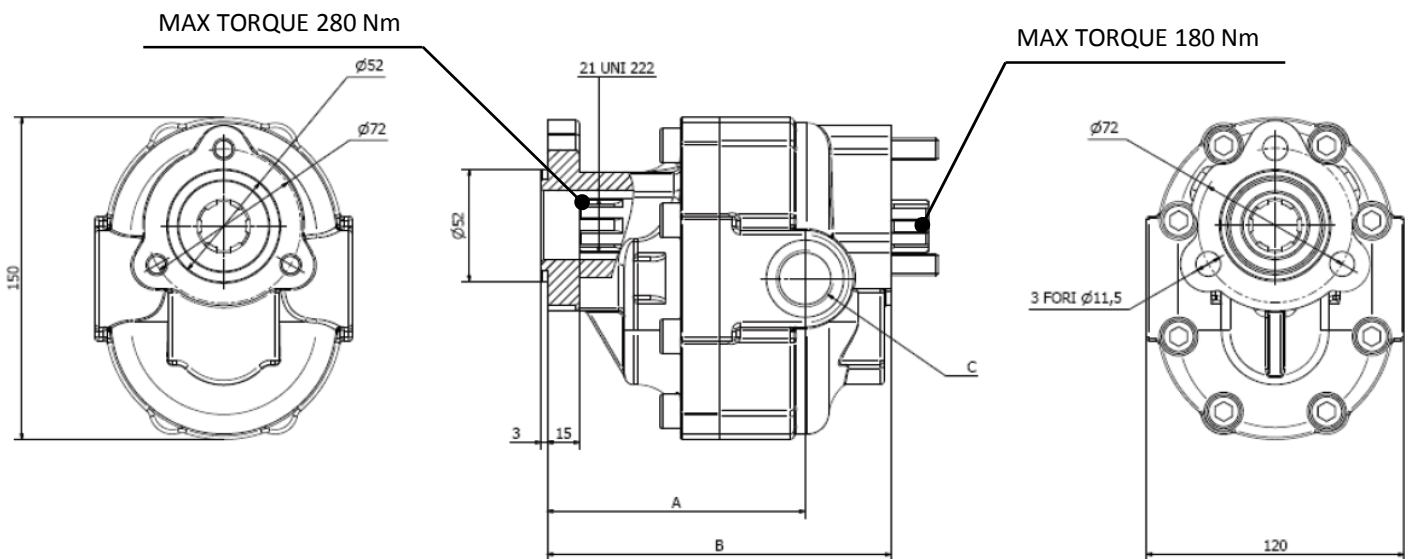

TIPO type	cm ³ /rev	A	B	C			Kg
				IN	OUT	BIDIR.	
032NFA-035	34,3	141	187	3/4"	1/2"	3/4"	15,0
032NFA-045	45,2	131	194	1"	3/4"	1"	15,5
032NFA-055	54,5	137	200	1"	3/4"	1"	16,1
032NFA-064	63,9	143	206	1"	3/4"	1"	16,9
032NFA-080	78,7	143	216	1"-1/4	1"	1"-1/4	17,3

Kit per pompe tandem Kit for tandem pumps

NFA 3

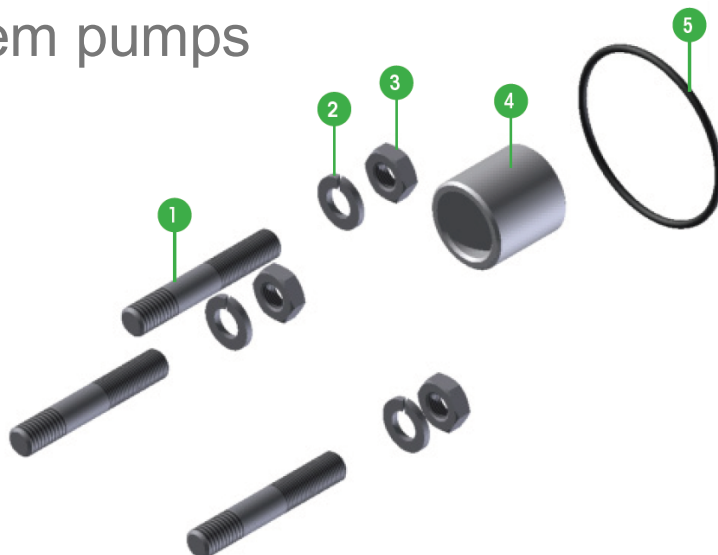

Rif.	Descrizione	Description	Qt.
1	Prigioniero	Stud	3
2	Rondella	Washer	3
3	Dado	Nut	1
4	Giunto	Coupling	1
5	Guarnizione	Gasket	1

Supporto pompe ISO Integrated bearings for ISO pump

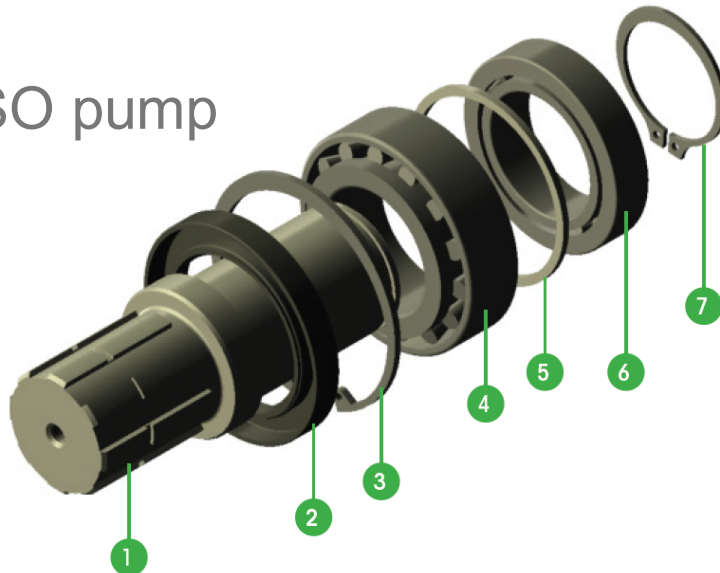

Rif.	Descrizione	Description	Qt.
1	Albero	Shaft	1
2	Paraolio	Shaft seal	1
3	Seeger	Snap ring	1
4	Cuscinetto	Roller bearing	1
5	Rondella	Washer	1
6	Cuscinetto	Roller bearing	1
7	Seeger	Snap ring	1